

SEALING

VIBRATION
CONTROL

CABIN
AIR FILTER

科帝克产品培训

Vibration Control Product 减振控制产品

Forest Hu



 Vibracoustic

Oct, 24th 2019



a brand of  FREUDENBERG

 CORTECO[®]

SEALING

VIBRATION
CONTROL

CABIN
AIR FILTER

Freudenberg OE quality for the IAM.















Freudenberg Group, our parent company.

The Freudenberg Group is worldwide recognized by the most important car manufacturers as leader in dynamic sealing, vibration technology control parts and cabin air filters.

 Trelleborg Vibracoustic



Vibracoustic is the Freudenberg Group trade mark for vibration control technology components.

| | | |
|--|---|--|
|  Audi |  |  |
|  |  |  |
|  |  |  |
|  |  |  |
|  | VOLVO |  SEAT |

a brand of  **FREUDENBERG**

 **CORTECO**[®]

原厂品质的配件

- 空调滤清器
- 活性炭空调滤清器
- 发动机进气空气滤清器



- 油封
- 编码器油封
- 密封垫和螺旋
- 排油塞
- 气门油封
- 气门
- 密封胶
- 制动软管

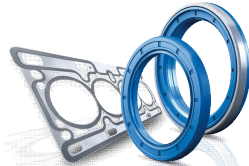

- 发动机和变速箱悬置
- 皮带轮
- 悬挂产品
- 液压蓄能器
- 弹性联轴器
- 底盘和传动系统轴承

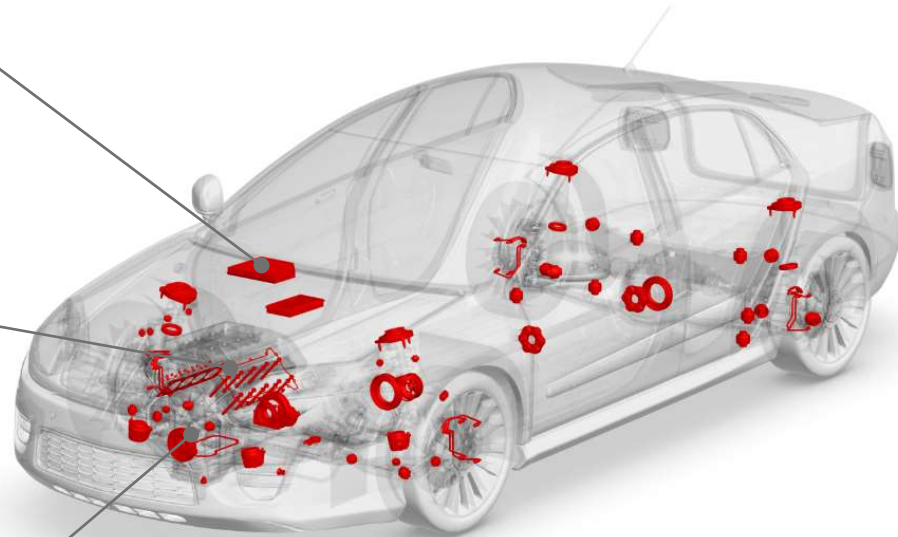

SEALING

VIBRATION
CONTROL

CABIN
AIR FILTER

您的驾驶舒适， 我们的个人动力

原厂品质的减振元件产品



 Vibracoustic

a brand of  FREUDENBERG

Page 4 5/12/2020 Name of Presentation

 CORTECO®

SEALING

VIBRATION
CONTROL

CABIN
AIR FILTER

振动控制

我们的四个强项

传动系统



动力系统

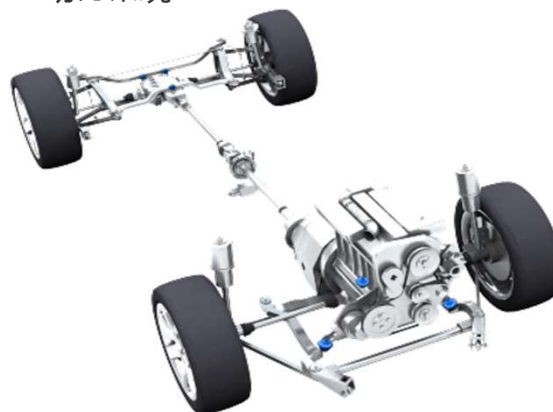

4

转向及结构件



滑柱系统





减振控制产品

基于科德宝丰富的原材料以及专业技术发展，我们为超过27,500种车型提供原厂品质的减震元件和维修套件。

所有的产品都按照最高的质量标准设计，并用最新的生产工艺制造。

振动往往是由于老化的部件或者低质量的减震部件引起的。不必要的振动会蔓延至整个车辆，并引起发动机和其他部件的损害。

- 减振元件的产品包含 2,275个商品
- 255 皮带轮
 - 50 启停皮带轮
 - 50 包含皮带轮，螺旋和垫圈的套件
- 超过1500发动机悬置
- 290 悬挂支架
 - 125 带球轴承的悬挂支架

SEALING

VIBRATION
CONTROL

CABIN
AIR FILTER

发动机悬置系统

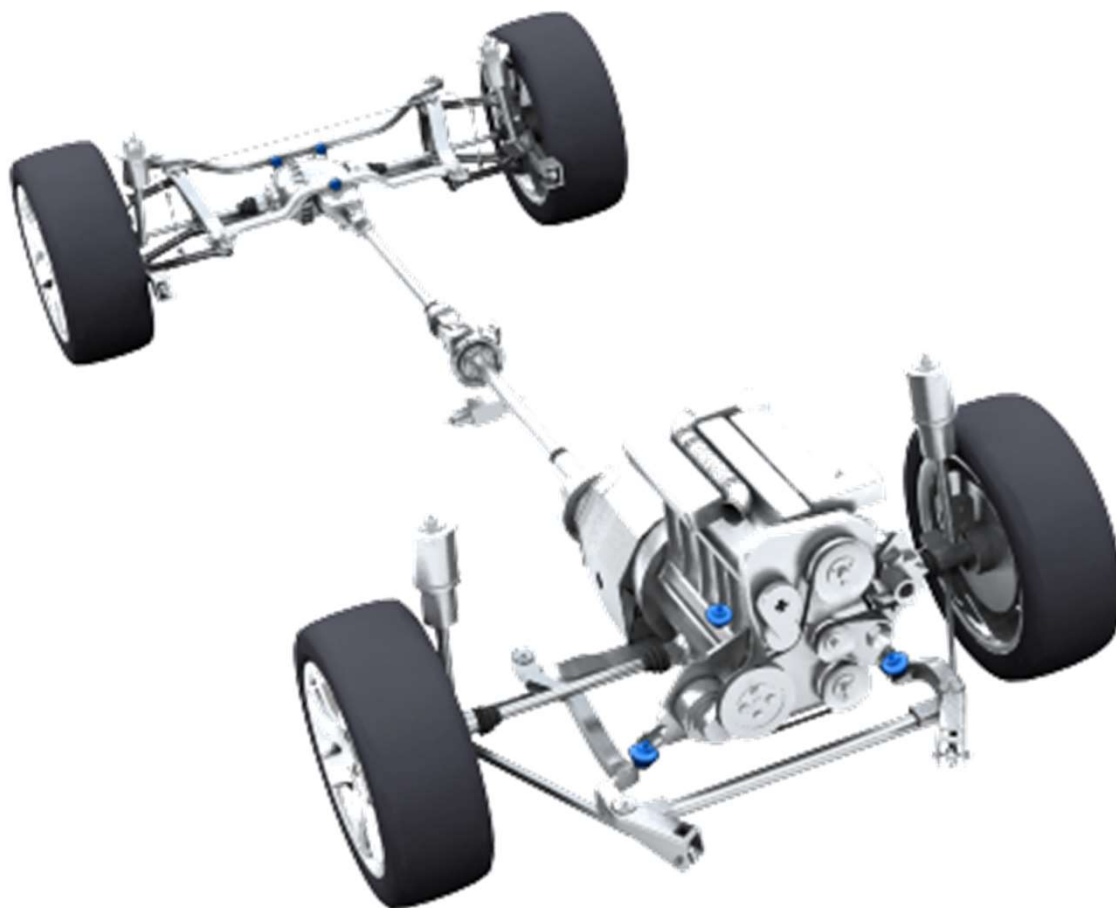

发动机悬置功能

支撑：

- 发动机重量
- 扭矩力
- 发动机运动相关
加速和减速

隔离：

- 噪音（高频）
- 振动（低频）
- 加速和减速冲击力

阻尼：

- 发动机晃动（路况 + 低频率）
- 噪音（高频 + 微抖）

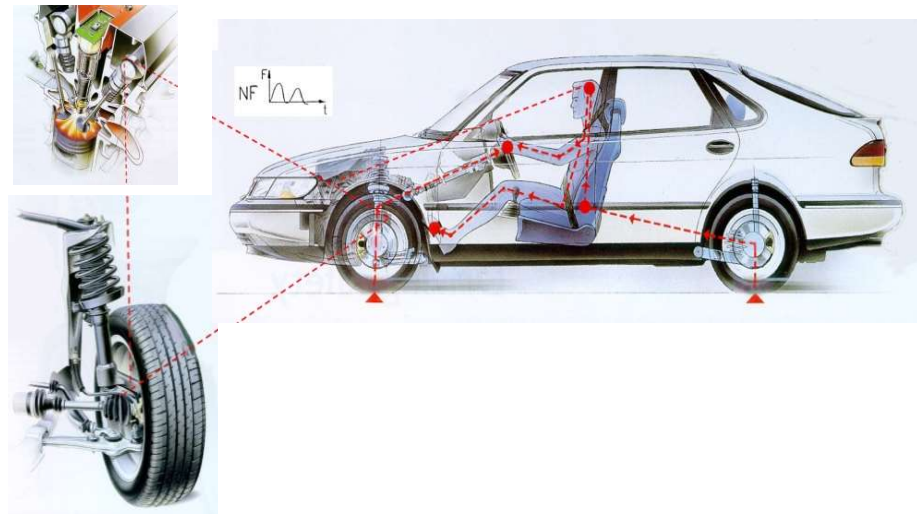

SEALING

VIBRATION CONTROL

CABIN AIR FILTER

发动机悬置发展趋势

纯胶悬置

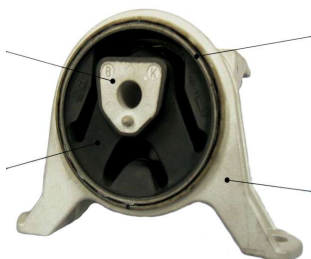

液压悬置

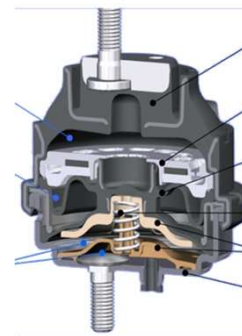
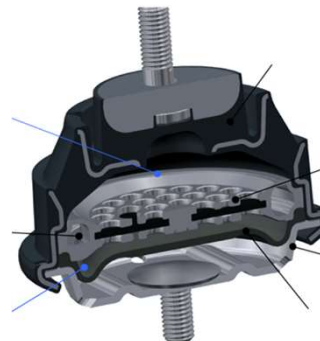

真空式半主动悬置



电磁式半主动悬置

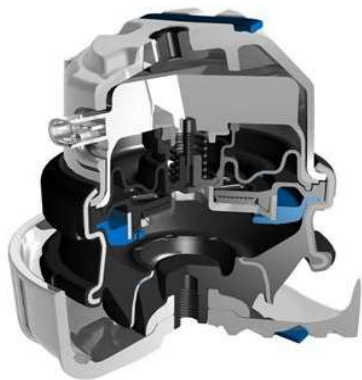

SEALING

VIBRATION
CONTROL

CABIN
AIR FILTER

第一代纯胶悬置



SEALING

VIBRATION
CONTROL

CABIN
AIR FILTER

第二代液压悬置

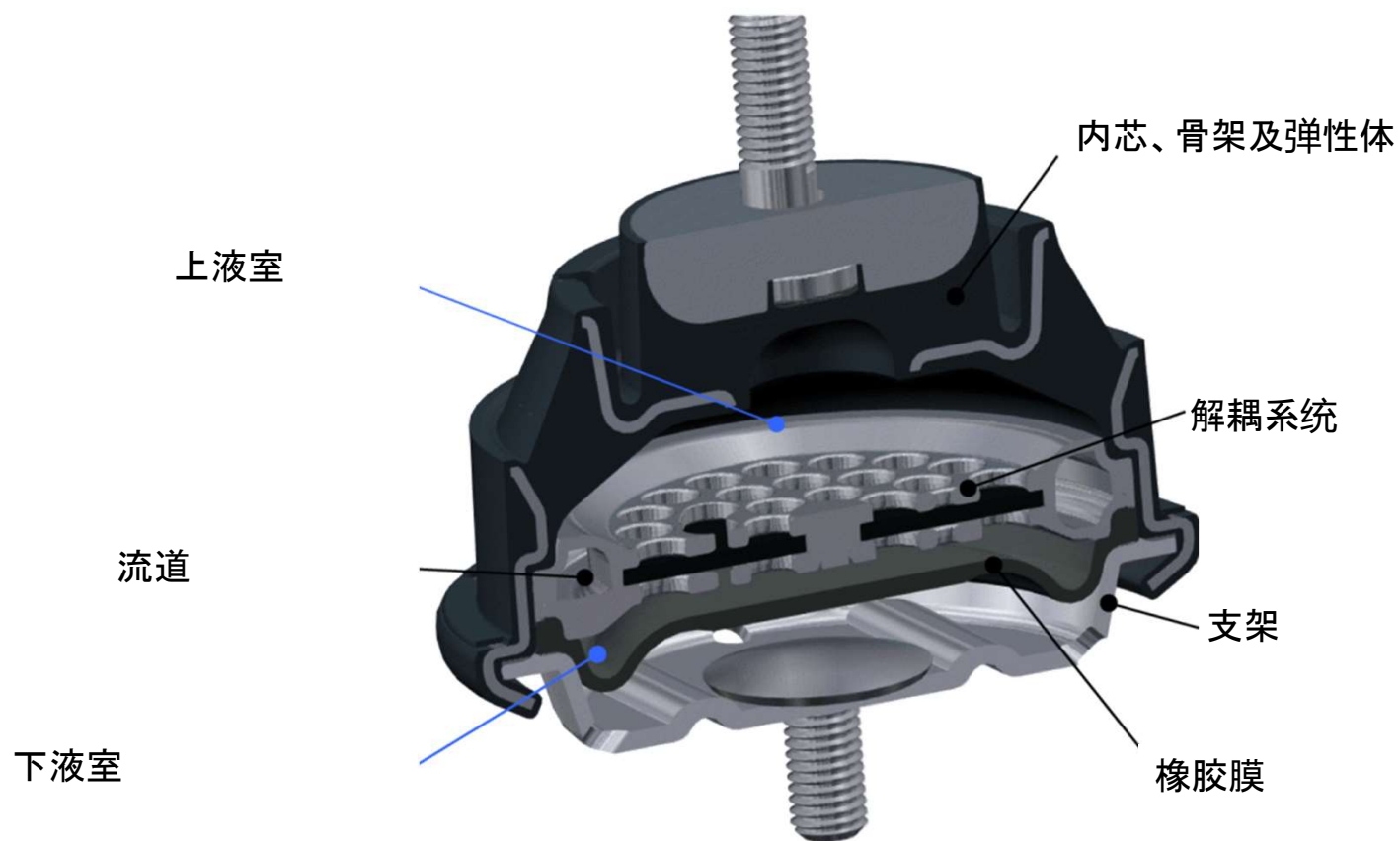

SEALING

VIBRATION
CONTROL

CABIN
AIR FILTER

第三代真空式半主动悬置

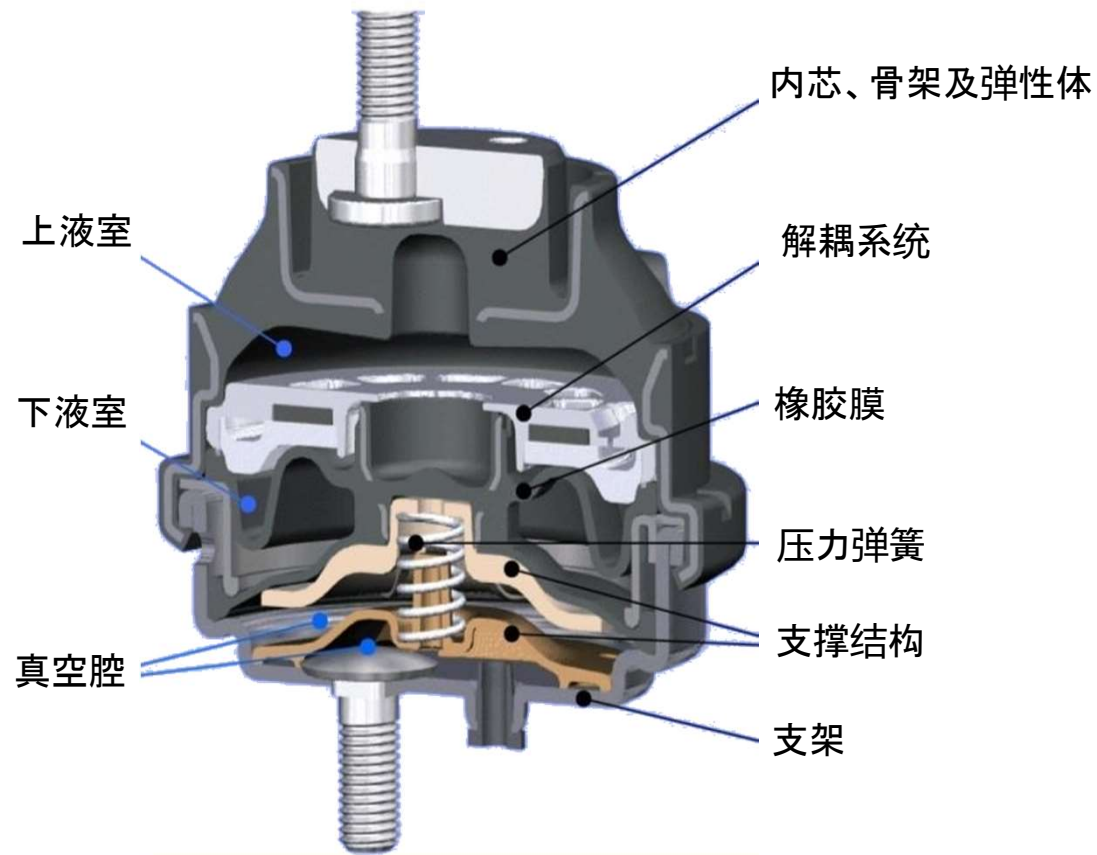

SEALING

VIBRATION
CONTROL

CABIN
AIR FILTER

第四代电流变(磁流变)半主动悬架

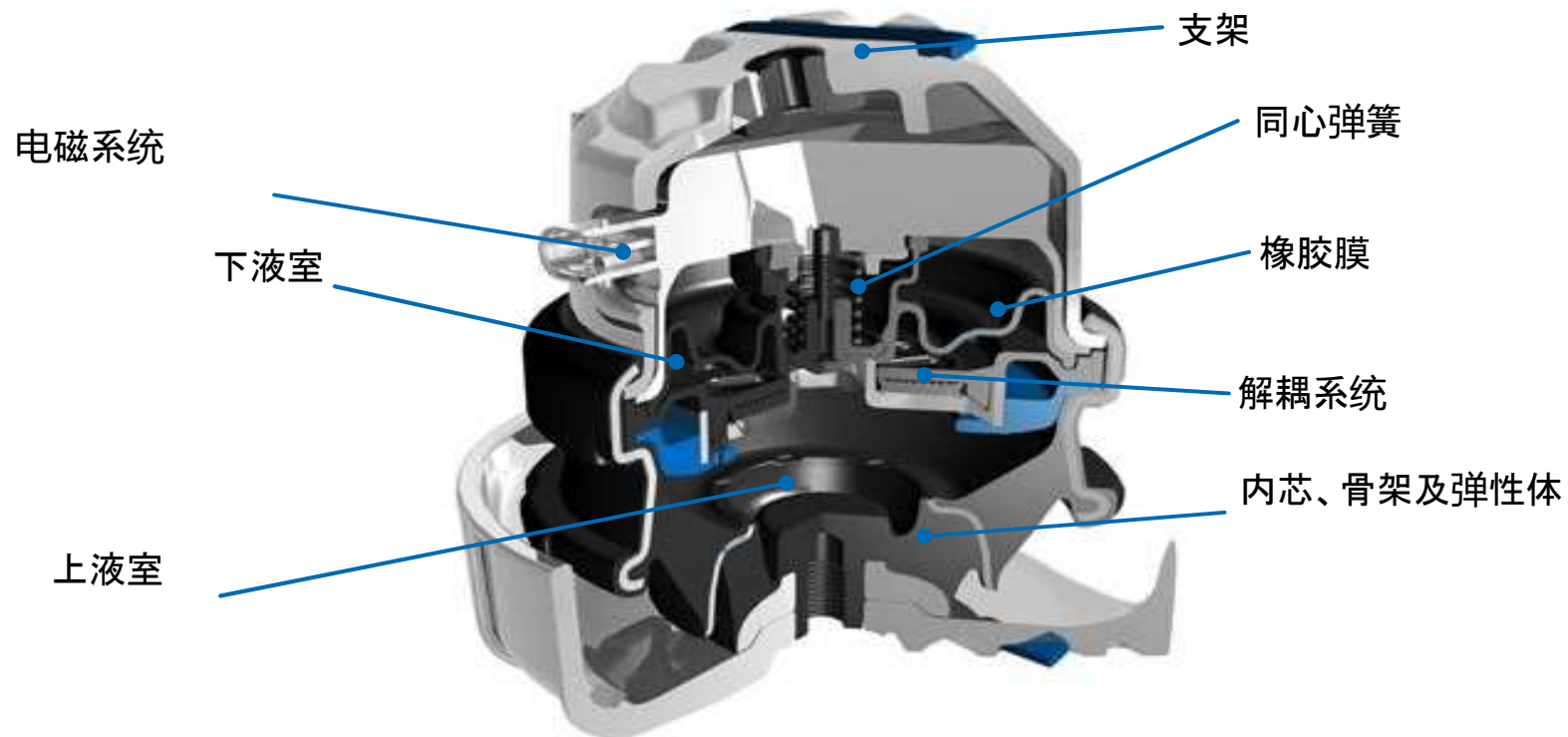

什么时候需要更换悬置

- 在噪音和振动变大的情况下
- 在发动机舱发出敲击噪音时
- 当发动机悬置有磨损
- 在发动机悬置内的橡胶部件大面积龟裂
- 在发动机悬置橡胶出现“大裂纹”和“折叠”的情况下



不及时更换发动机悬置的后果

- 发动机产生的大振动和噪音导致驾驶乐趣降低
- 发动机悬置磨损后，发动机运动变大，冲击力大，导致与发动机连接的所有部件出现严重问题

结果？可能损坏：

- 车轴
- 冷却系统
- 排气系统
- 燃油喷射系统
- 风扇
- 燃油管路



SEALING

VIBRATION
CONTROL

CABIN
AIR FILTER

不及时更换发动机悬置的风险



SEALING

VIBRATION
CONTROL

CABIN
AIR FILTER



Renault E.M.
Benchmark

看不见的差异

售后市场，低质量的零件和仿件存在，很难在第一眼就区分出来。
只有通过切割才能发现：



“原始”仿件：

完全缺乏液压阻尼功能

不可能控制振动

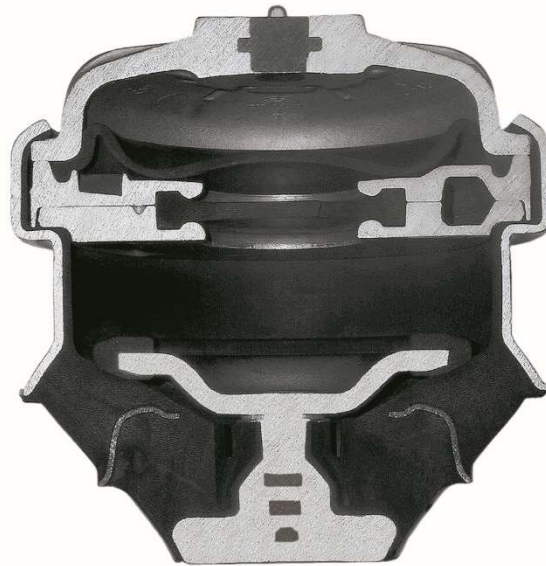

原装质量：

完美匹配 OE 要求

完美的振动控制和持久

100% 等效于 OE



高仿假件：

液压结构无测试

性能差

使用寿命降低

性能曲线图对比

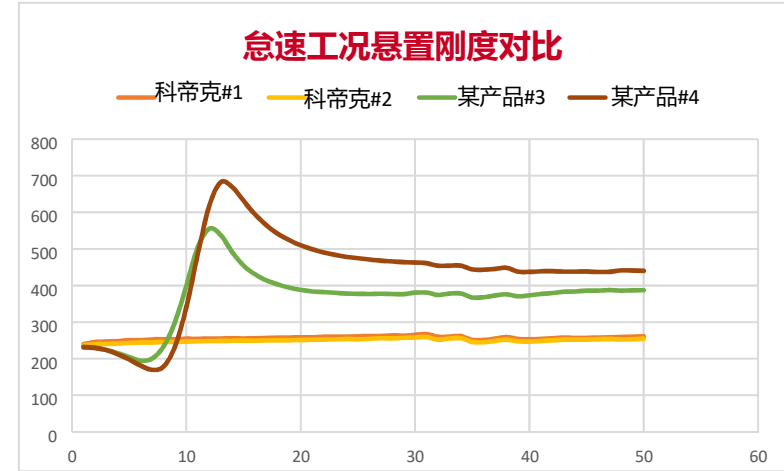
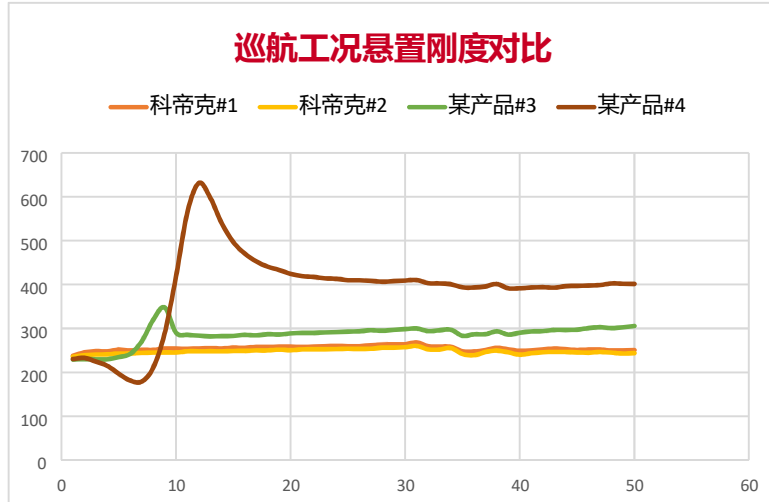

科帝克1#、2#悬置性能表现一致性好，波形平顺，无突变峰值，且其平均性能好。在振动时，有利于振动的隔离，提升驾驶舒服感。

某产品3#、4#悬置表现一致性很差，刚度存在突变，波形峰值高，曲线不平顺，性能差。装车后容易造成怠速及加速抖动，并连带动力性能下降，并对发动机相关零件造成疲劳损害，最终造成客户损失。

发动机悬置的重要性

由于发动机本身是一个内在的振动源，同时也受到来自外部的各种振动干扰，引起零部件的损坏和乘坐的不舒适等，所以设置悬置系统，把发动机传递到支承系统的振动减小到最低限度。成功地控制振动，主要取决于悬置系统的结构型式、几何位置及悬置软垫的结构、刚度和阻尼等特性，确定一个合理的悬置系统是一件相当复杂的工作，它要满足一系列静态及动态的性能要求，同时又受到各种条件的约束，这些大大增加了设计的难度。

我们的优势

随着主机厂对NVH整车性能要求的不断提高，第三代真空室半主动悬置的普及应用至2022年会达到30%，电磁式半主动悬置VIO提高到20%，这正是我们在技术上的优势体现。选择科帝克，成为品质的领先者。



曲轴皮带轮



扭转振动减震器 – 单独包装和带螺栓套装

扭转振动减震器将皮带和曲轴耦合在一起，它最大限度的减轻了振动的传递以及最小化了所有连接部件的压力。皮带以及皮带张紧器的寿命得到延长，并且极大的增加了驾驶的舒适性。

只有配有新的螺栓的原厂质量的皮带轮可以确保最高级别的安全性。

- 255个皮带轮
 - 50 个启停皮带轮
- 50 个包含皮带轮和螺栓的套件
- 54 螺栓套包
- 欧系和亚洲车型完整的皮带轮产品线

SEALING

VIBRATION
CONTROL

CABIN
AIR FILTER

皮带轮：我们的领域

应用于各类发动机的专属皮带轮

扭转减振器

- 压装
- 硫化

解耦皮带轮

凸轮轴扭转减振器

特殊扭转减振器



SEALING

VIBRATION
CONTROL

CABIN
AIR FILTER

结构范例.

汽油机应用



1,8 l
R4
OTTO

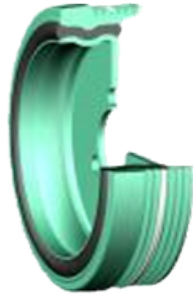

1,6 – 2,0 l
R4
OTTO



1,4 – 1,8 l
R4
OTTO



4,5 l
V8
OTTO



6,0 l
W12
OTTO

SEALING

VIBRATION
CONTROL

CABIN
AIR FILTER

结构范例.

柴油机应用

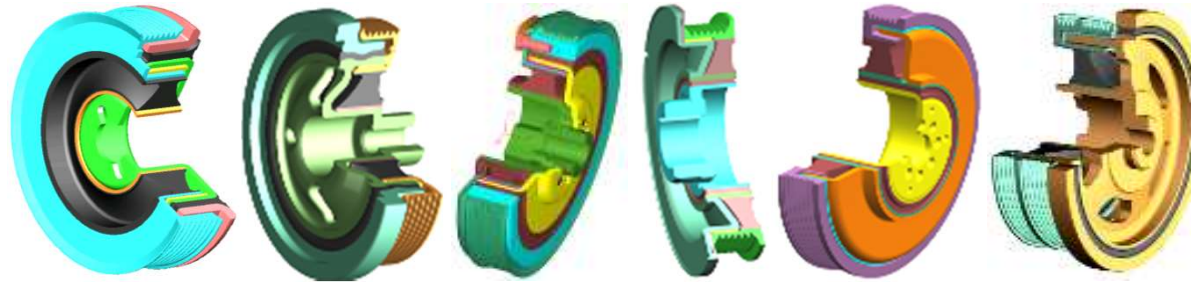

1,5 – 2,0 l
R4
TD – OTTO



2,0 l
R4
CR



2,5 l
R5
TDI



2,0 – 2,2 l
R4
DI



3,0 l
V6
TDI



2,0 l
R4
CR

单极曲轴皮带轮构造

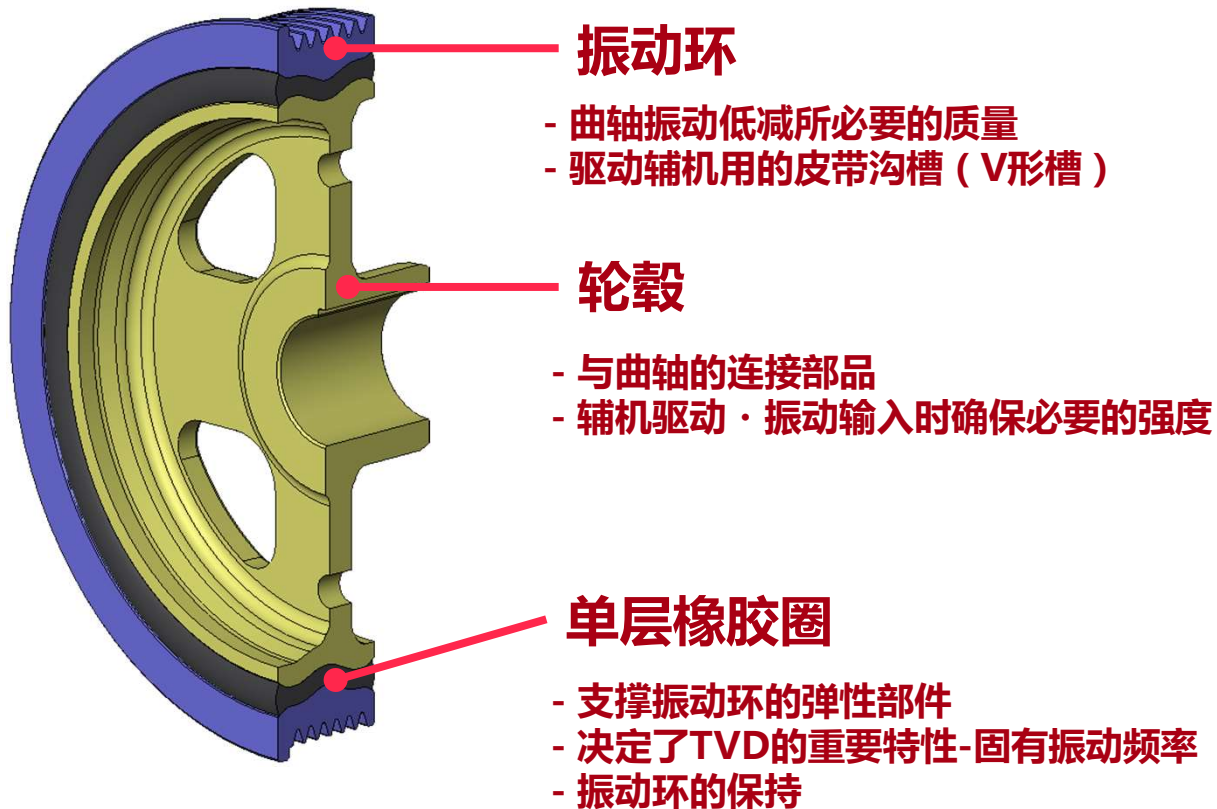

SEALING

VIBRATION CONTROL

CABIN AIR FILTER

单极vs多级耦合式曲轴皮带轮



标准皮带轮

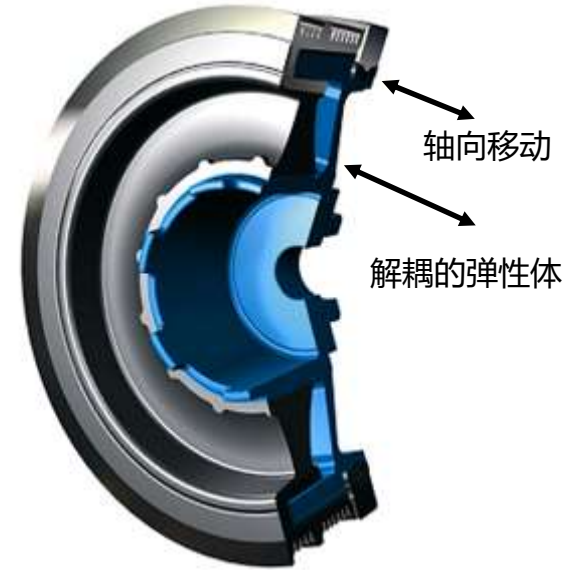

解耦皮带轮

80000873皮带轮截面



多级耦合式皮带轮好处及维护

特殊产品、特别维护

好处:

- 延长皮带和张紧器的使用寿命
- 降低发动机噪音水平
- 减少对皮带和相关附件的压力

定期检查:

- 每 90.000 公里检查
- 一起更换皮带轮、皮带和张紧器
- 发生事故时, 请仔细检查皮带轮

安装步骤:

- 仔细遵循制造商提供的安装/拆卸指导
- 请勿将不合适的工具用于作业
- 螺栓须与皮带轮一起更换
- 按照说明打扭距

SEALING

VIBRATION
CONTROL

CABIN
AIR FILTER

多级耦合式皮带轮，转动功效

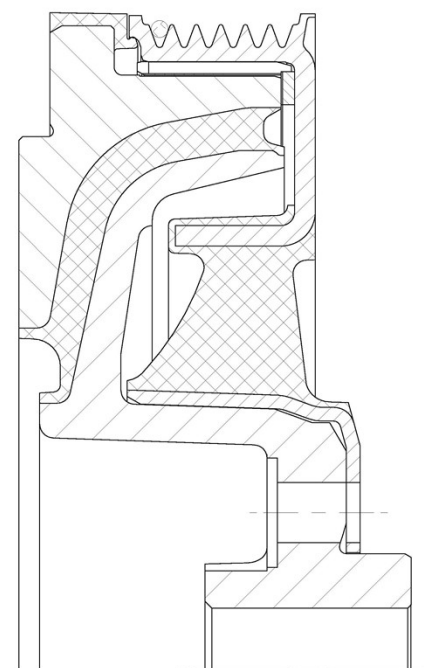
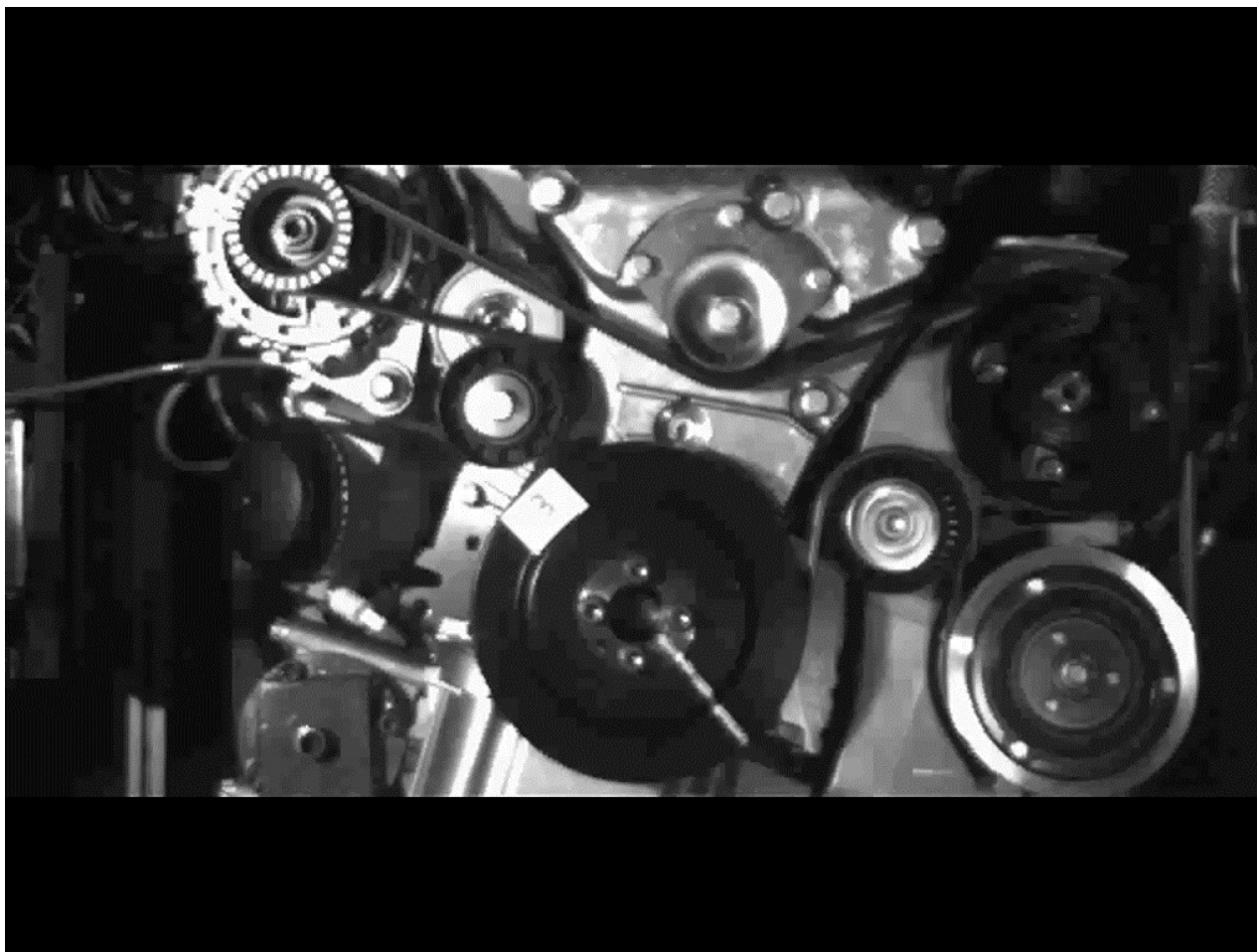

SEALING

VIBRATION CONTROL

CABIN AIR FILTER

BMW皮带轮. OE vs 仿品. 应力模型.

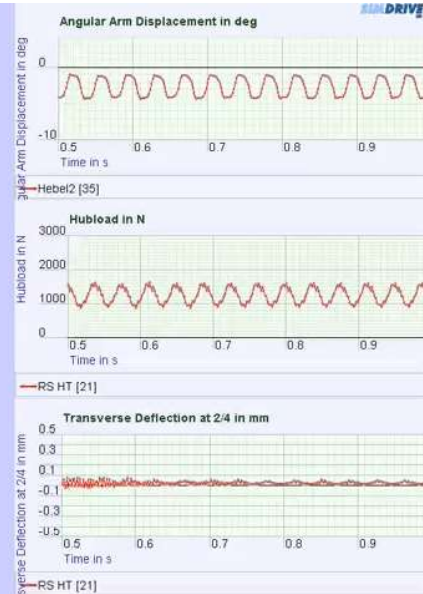
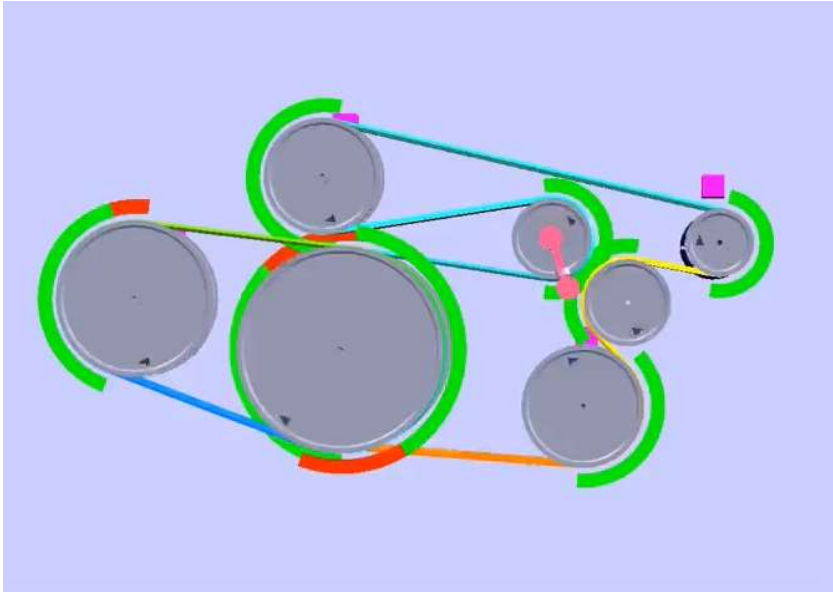

张紧轮移动

轴承载荷

皮带振动

Copy

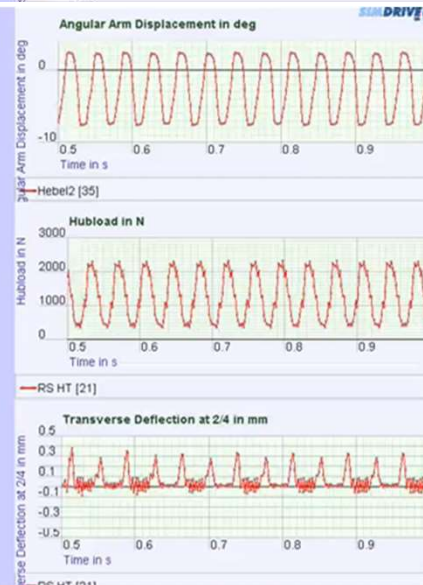
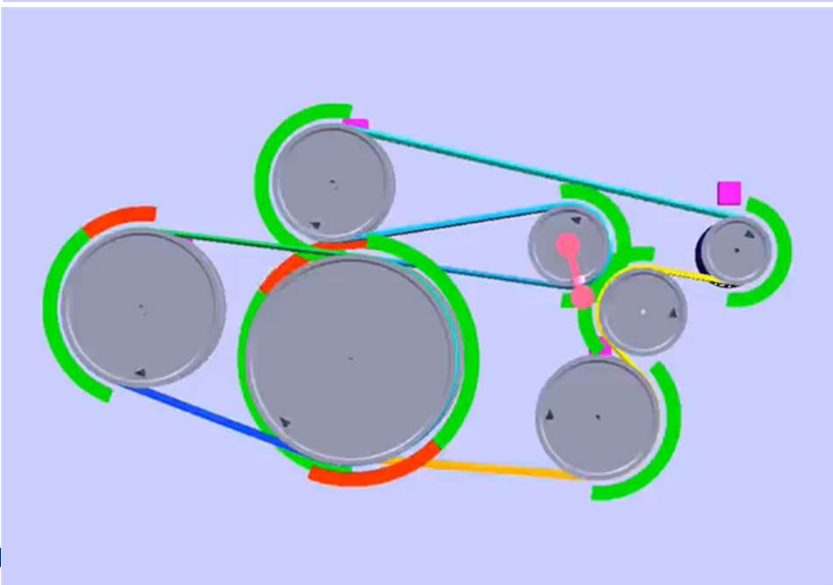

张紧轮移动

轴承载荷

皮带振动

a brand of



SEALING

VIBRATION
CONTROL

CABIN
AIR FILTER

原厂品质配件 vs 仿制品

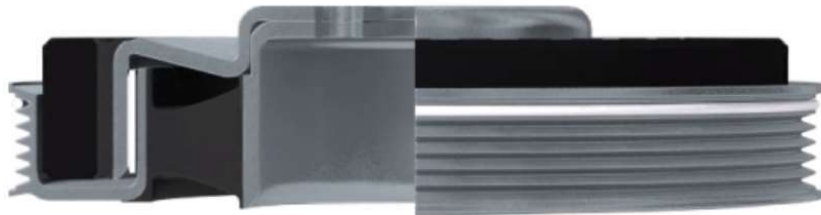

Corteco 原厂品质皮带轮

配制的弹性体材料，专门开发的橡胶-金属粘合技术和粘性油配方

- 最佳的振动吸收
- 噪音的减少

只有带新螺栓的原厂品质的皮带轮可以确保最高级别的安全性

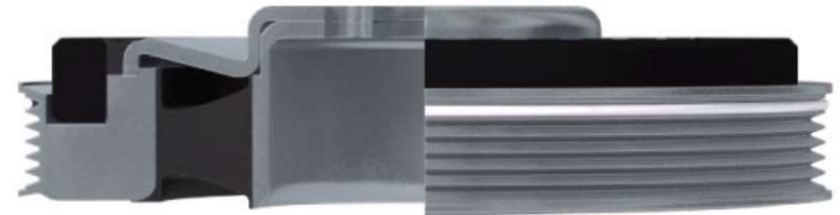

仿制的皮带轮

只有金属部分以及没有或者很少的橡胶材料，会导致：

- 增加的振动导致损坏发动机和辅助装置的风险
- 增加发动机噪音

没有产品横截图的话，从表面是很难区分仿制的皮带轮，所以最简单的方式是相信科帝克原厂品质皮带轮专家

皮带轮橡胶材料

| 橡胶材料 | 常用温度 | 最高温度 |
|-----------|-------|-------|
| N R | 80°C | 100°C |
| N B R | 100°C | 110°C |
| C R | 100°C | 120°C |
| S B R | 100°C | 130°C |
| E P D M | 100°C | 140°C |
| V A M A C | 100°C | 150°C |

曲轴皮带轮用的橡胶材料，主要以EPDM三元乙丙橡胶为主，这种材料具有更优秀的抗压强及抗扭振性能。

正品vs仿品(80004350 example)

- 正时标记：安装过程中的正确定位需要
- 滑动轴承：接触面不平，配合太松。产生过度振动及热量，导致使用寿命缩短
- 涂漆滑动轴承表面：导致轴承摩擦增加，由于过热导致轴承卡死失效，寿命缩短
- 不是 OE 参数的橡胶：导致阻尼功能不良，使用寿命缩短



1. 正时标记

3. 滑动轴承表面涂漆

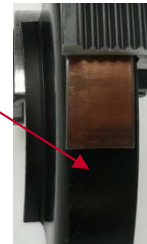

2. 糟糕的公差配合

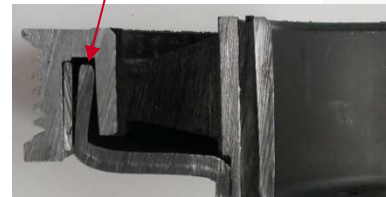

4. 弹性体



1. No OT marking

Corteco 皮带轮售后市场分析



2017年

国内市场TVD需求量超2800万只，单极TVD占据90%份额，多级耦合式TVD不到7%



2020年

整体需求突破3500万只，其中多级耦合式TVD市场份额提升至10%-15%，达到525万只



2022年

科帝克应用在中高级耦合式TVD的车型覆盖率将达到75%

依托NOK+Freudenberg在橡胶+减振领域的市场优势，科帝克将带给客户更多具有领先技术的产品。

SEALING

VIBRATION
CONTROL

CABIN
AIR FILTER



Place of presentation, date
Author with title, first name, last name

感谢聆听！

